

General Description

The Gotop GT-1110-MT is a complete GPS engine module that features super sensitivity, ultra low power and small form factor. The GPS signal is applied to the antenna input of module, and a complete serial data message with position, velocity and time information is presented at the serial interface with NMEA protocol or custom protocol.

Its -165dBm tracking sensitivity extends positioning coverage into place like urban canyons and dense foliage environment where the GPS was not possible before. The small form factor and low power consumption make the module easy to integrate into portable device like PNDs, mobile phones, cameras and vehicle navigation systems.

Applications

- LBS (Location Based Service)
- PND (Portable Navigation Device)
- Vehicle navigation system
- Mobile phone



Figure: GT-1110-MT Top View

Features

- Build on high performance, low-power MediaTek MT3339 chip set
- Ultra high Track sensitivity: -165dBm
- Extremely fast TTFF at low signal level
- Built in high gain LNA
- Low power consumption: Max $28\text{mA}@3.3\text{V}$
- NMEA-0183 compliant protocol or custom protocol
- Operating voltage: 2.8V to 4.3V
- Operating temperature range: $-40\text{to}85^\circ\text{C}$
- SMD type with stamp holes
- Small form factor: $10.1\times 9.7\times 2.2\text{mm}$
- RoHS compliant (Lead-free)

1 Description	3
1.1 General Description.....	3
1.2. Key Features.....	4
1.3. Block Diagram.....	5
1.4. Protocols Supported by the Module.....	5
2 Application	6
2.1. Pin Assignment.....	6
2.2. Pin Definition.....	6
2.3. Power Supply.....	8
2.4. Operating Modes.....	10
2.4.1. Full on Mode.....	10
2.4.2. Standby Mode.....	11
2.4.3. Backup Mode.....	11
2.4.4. Periodic Mode.....	13
2.4.5. AlwaysLocate™ Mode.....	14
2.4.6. FLP Mode.....	15
2.5. UART Interface.....	16
2.6. EASY Technology.....	17
2.7. Multi-tone AIC.....	18
2.8. LOCUS.....	18
2.9. PPS VS. NMEA.....	19
3 Antenna Interfaces	19
3.1. PCB Design Guide.....	19
3.2. External Active Antenna.....	20
4 Electrical, Reliability and Radio Characteristics	21
4.1. Absolute Maximum Ratings.....	21
4.2. Operating Conditions.....	21
4.3. Current Consumption.....	22
4.4. Electrostatic Discharge.....	22
4.5. Reliability Test.....	23
5 Mechanical Dimensions	23
6 Manufacturing, Packaging and Ordering Information	24
6.1. Assembly and Soldering.....	24
6.2. Moisture Sensitivity.....	24
6.3. ESD Protection.....	24
6.4. Tape and Reel Packaging.....	25
7 Appendix References	26
8 NMEA 0183 Protocol	27

1 Description

1.1 General Description

GOTOP GT-1110-MT GPS module embedded LNA brings high performance of MTK positioning engine to the industrial applications. It is able to achieve the industry's highest level of sensitivity, accuracy and TTFF with the lowest power consumption in a small-footprint leadless package. With 66 search channels and 22 simultaneous tracking channels, it acquires and tracks satellites in the shortest time even at indoor signal level. The embedded flash memory provides capacity for users to store some useful navigation data and allows for future updates.

GT-1110-MT module combines many advanced features including EASY, AIC, LOCUS, AlwaysLocate™, FLP. These features are beneficial to accelerate TTFF, improve sensitivity, save consumption. The module supports various positioning, navigation and industrial applications, including autonomous GPS, SBAS (including WAAS, EGNOS, MSAS, and GAGAN), QZSS, and AGPS.

EASY technology as the key feature of GT-1110-MT is one kind of AGPS. Capable collecting and processing all internal aiding information like GPS time, Ephemeris, Last Position, etc., the GPS module delivers a very short TTFF in either Hot or Warm start.

GT-1110-MT module is a SMD type module with the compact 10.1mm × 9.7mm × 2.2mm form factor. It can be through the 18-pin pads embedded in your applications. It provides necessary hardware interfaces for connection with the main PCB.

Made of lead-free technology, conforms to the RoHS standard, Single patch, two times more rapid application of SMT scheme.

1.2. Key Features

Table 1: Key Features

Parameter	Specification
Power Supply	<ul style="list-style-type: none"> Supply voltage: 2.8V~4.3V Typical: 3.3V
Power Consumption	<ul style="list-style-type: none"> Acquisition: 28mA @VCC=VBAT=3.3V Tracking: 20mA @VCC=VBAT=3.3V Standby: 1.0mA @VCC=VBAT=3.3V Backup: 7uA @VBAT=3.3V
Receiver Type	<ul style="list-style-type: none"> Code 66 search channels, GPS&QZSS L1 1575.42MHz C/A 22 simultaneous tracking channels
Sensitivity	<ul style="list-style-type: none"> Tracking: -165dBm Re-acquisition: -156dBm Acquisition: -148dBm
TTF (EASY enabled)	<ul style="list-style-type: none"> Cold start: 15s typ @-130dBm Warm start: 5s typ @-130dBm Hot start: 1s typ @-130dBm
TTF (EASY disabled)	<ul style="list-style-type: none"> Cold start(Autonomous): 35s typ @-130dBm Warm start (Autonomous): 30s typ @-130dBm Hot start (Autonomous): 1s typ @-130dBm
Horizontal Position Accuracy (Autonomous)	<ul style="list-style-type: none"> <2.5m CEP @-130 dBm
Max Update Rate	<ul style="list-style-type: none"> Up to 10Hz, 1Hz by fault
Accuracy of 1PPS Signal	<ul style="list-style-type: none"> Typical accuracy: ±10ns Time pulse width 100ms
Acceleration Accuracy	<ul style="list-style-type: none"> Without aid: 0.1m/s²
Dynamic Performance	<ul style="list-style-type: none"> Maximum altitude: 18,000m Maximum velocity: 515m/s Acceleration: 4G
UART Port	<ul style="list-style-type: none"> UART Port: TXA and RXA Supports baud rate from 4800bps to 115200bps, 9600bps by default UART port is used for NMEA output, MTK proprietary commands input and firmware upgrade
Temperature Range	<ul style="list-style-type: none"> Normal operation: -40°C ~ +85°C Storage temperature: -45°C ~ +125°C
Physical Characteristics	<ul style="list-style-type: none"> Size: 10.1±0.15 × 9.7±0.15 × 2.2±0.1mm Weight: Approx. 0.41g

1.3. Block Diagram

The following figure shows a block diagram of GT-1110-MT module. It consists of a single chip GPS IC which includes the RF part and Baseband part, a LNA, a SAW filter, a TCXO, a crystal oscillator.

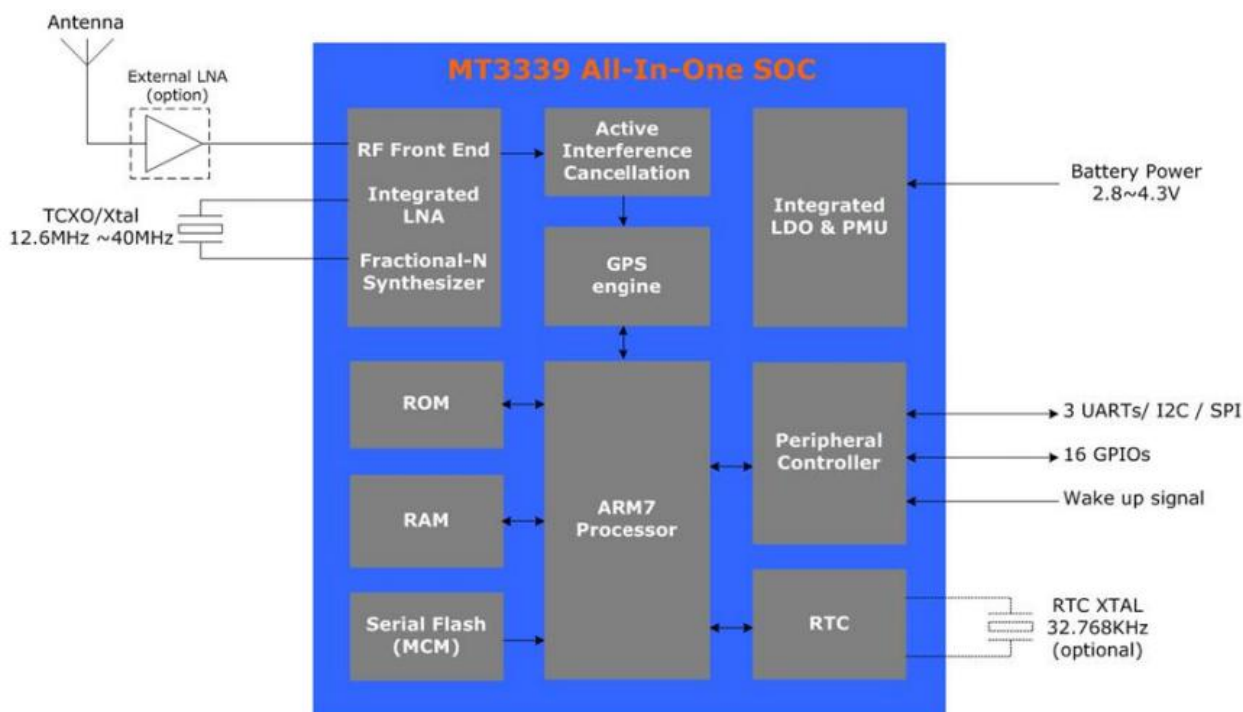

Figure 1: Block Diagram

1.4. Protocols Supported by the Module

Table 2: Protocols Supported by the Module

Protocol	Type
NMEA	Output, ASCII, 0183, 3.01
PMTK	Input, MTK proprietary protocol

2 Application

The module is equipped with a 18-pin SMT pad that connects to your application platform. Sub-interfaces included in the pad are described in details in the following chapters.

2.1. Pin Assignment

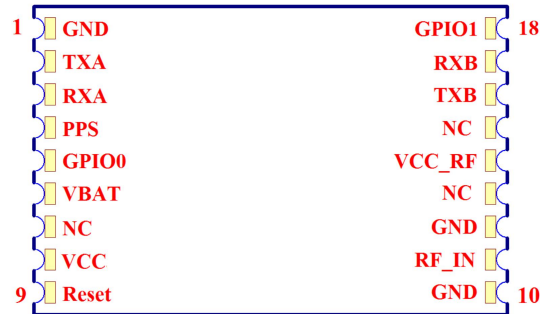

Figure 2: Pin Assignment

2.2. Pin Definition

Power Supply					
Pin Name	Pin No.	I/O	Description	DC Characteristics	Comment
VCC	8	I	Main power supply	Vmax=4.3V Vmin=2.8V Vnom=3.3V	Supply current not less than 100mA.
VBAT	6	I	Backup power supply	Vmax=4.3V Vmin=1.5V Vnom=3.3V	Supply power for RTC domain. The VBAT pin can be directly supplied power by battery or connect it to VCC.
GND	1,10,12	G	Ground.		Assure a good GND connection to all GND pins of the module, preferably with a large ground plane.
Reset					
Pin Name	Pin No.	I/O	Description	DC Characteristics	Comment
RESET	9	I	System reset	VILmin=-0.3V VILmax=0.8V VIHmin=2.0V VIHmax=3.6V	Low level active. If unused, keep this pin open or connect it to VCC.

UART Port

Pin Name	Pin No.	I/O	Description	DC Characteristics	Comment
RXA	3	I	Receive data	VILmin=-0.3V VILmax=0.8V VIHmin=2.0V VIHmax=3.6V	
TXA	2	O	Transmit data	VOLmin=-0.3V VOLmax=0.4V VOHmin=2.4V VOHmax=3.1V	
RXB	17	I	Receive data	VILmin=-0.3V VILmax=0.8V VIHmin=2.0V VIHmax=3.6V	If not used, this pin is left vacant.
TXB	16	O	Transmit data	VOLmin=-0.3V VOLmax=0.4V VOHmin=2.4V VOHmax=3.1V	If not used, this pin is left vacant.

RF Interface

Pin Name	Pin No.	I/O	Description	DC Characteristics	Comment
RF_IN	11	I	External active antenna RF input		Characteristic impedance of 50Ω
VCC_RF	14	O	Active antenna power output	Vnom=3.3V	Output Voltage RF section. VCC_RF can be selected according to the type of antenna.

Other Interfaces

Pin Name	Pin No.	I/O	Description	DC Characteristics	Comment
PPS	3	O	One pulse per second	VOLmin=-0.3V VOLmax=0.4V VOHmin=2.4V VOHmax=3.1V	Synchronized at rising edge, the pulse width is 100ms. If unused, keep this pin open.

GPIO Interfaces

Pin Name	Pin No.	I/O	Description	DC Characteristics	Comment
GPIO0	5	I/O	General purpose I/O		If not used, this pin is left vacant.
GPIO1	18	I/O	General purpose I/O		If not used, this pin is left vacant.

2.3. Power Supply

VCC pin supplies power for BB, RF, I/O, LNA, short protection and antenna detection circuit. The load current of VCC varies according to the VCC level, processor load, the number of tracked satellites and the rate of satellite re-acquisition. Using external active antenna will consume additional 11mA from our module. So it is important to supply sufficient current and make the power clean and stable. VCC supply ripple voltage should meet the requirement: 54mV (RMS) max @f=0...3MHz and 15mV (RMS) max@f >3MHz. You should choose the LDO without built-in output high-speed discharge function to keep long output voltage drop-down period. The decouple combination of 10uF and 100nF capacitor is recommended nearby VCC pin.

The VBAT pin supplies power for RTC domain. It should be valid when power on the module. The voltage of RTC domain ranges from 1.5V to 4.3V. In order to achieve a better TTFF, RTC domain should be valid all the time. It can supply power for SRAM memory in RTC domain which contains all the necessary GPS information for quick start-up and a small amount of user configuration variables.

✧ The module's internal power construction is shown as below.

VCC supplies power for PMU, and VBAT supplies power for RTC domain. TIMER signal highlighted in red in the following figure belongs to RTC domain and can be used to control the power switch on/off.

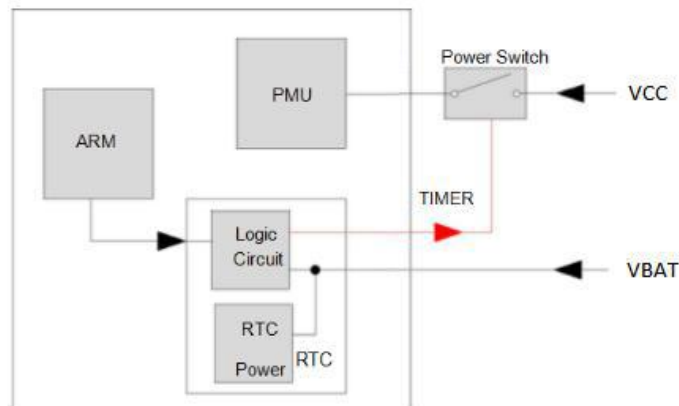

Figure 3: Internal Power Construction

✧ Power supply solutions for GT-1110-MT module are listed as the following.

The simplest power circuit for GT-1110-MT module is 3.3V power source connected to VCC pin and VBAT pin of the module directly. In this case, once you powered on the module, the full cold start will be implemented.

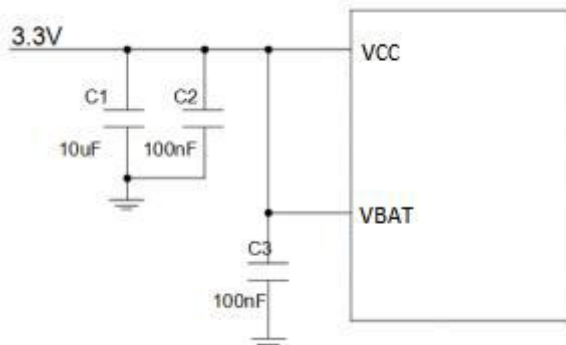

Figure 4: Reference Circuit for Power Supply

If your power supply circuit adopts the design mentioned above, GT-1110-MT module does not support EASY technology and backup mode as well as other modes related to it, e.g. AlwaysLocate™ backup mode.

The other way is feeding VBAT through a backup battery directly. The module will enter into backup mode when power source (3.3V) is cut off. Furthermore, it is necessary to add an external charging circuit for rechargeable battery. The detailed schematic (mount R2 with 0R to replace Power switch) is shown as there is no charge source when power source (3.3V) is cut off. MS621FE FL11E from Seiko is recommended. The consumption of VBAT is as low as 7µA in backup mode.

The schematic with power supply circuit is shown as below. As power source (3.3V) is always valid and the battery is charged continuously, the capacity of the battery can be small. The detailed schematic for power switch circuit is shown in **Figure 5**.

For more details about backup mode, periodic backup mode and AlwaysLocate™ backup mode, please refer to the related chapters.

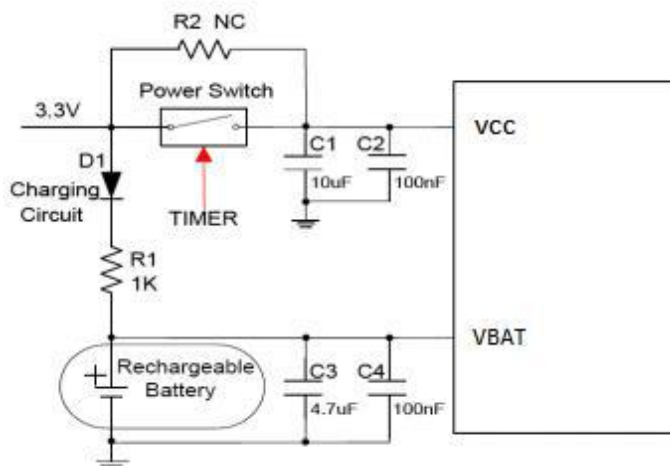

Figure 5: Reference Charging Circuit for Chargeable Battery

VCC does not supply power for RTC domain in GT-1110-MT module, so the VBAT pin must be powered externally. Furthermore, it is strongly recommended to supply power to VBAT through a backup battery, which can ensure GT-1110-MT module supports EASY technology and improves TTFF after next restart. For details about TTFF, please refer to *chapter 1.2*.

2.4. Operating Modes

The table below briefly illustrates the relationship among different operating modes of GT-1110-MT module.

Table 3: Module States Switch

Current Mode	Next Mode					
	Backup	Standby	Full on	Periodic	AlwaysLocate	FLP
Backup	N/A	N/A	Refer to <i>chapter 2.4.3</i>	N/A	N/A	N/A
Standby	N/A	N/A	Send any data via UART	N/A	N/A	N/A
Full on	Refer to <i>chapter 2.4.3</i>	PMTK161	N/A	PMTK225	PMTK225	PMTK262
Periodic	N/A	N/A	Refer to <i>chapter 2.4.4</i>	N/A	N/A	N/A
Always Locate	N/A	N/A	Refer to <i>chapter 2.4.5</i>	N/A	N/A	N/A
FLP	N/A	N/A	Refer to <i>chapter 2.4.6</i>	N/A	N/A	N/A

2.4.1. Full on Mode

Full on mode includes tracking mode and acquisition mode. Acquisition mode is defined as the module starts to search satellites, determine visible satellites and coarse carrier frequency as well as code phase of satellite signals. When the acquisition is completed, it switches to tracking mode automatically. Tracking mode is defined as the module keeps tracking satellites and demodulates the navigation data from the specific satellites.

When the combination of VCC and VBAT is valid, the module will enter into full on mode automatically and follow the default configurations as below. You can refer to *chapter 2.3* about internal power construction to have a good comprehension. You can also use PMTK commands to change the configurations to satisfy your requirements.

Table 4: Default Configurations

Item	Configuration	Comment
Baud Rate	9600bps	Can be configured as 4800bps~115200bps
Protocol	NMEA	RMC, VTG, GGA, GSA, GSV, GLL
Update Rate	1Hz	Can be configured as 1~10Hz
SBAS	Enable	
AIC	Enable	
LOCUS	Disable	
EASY	Enable	EASY will be disabled automatically when update rate exceeds 1Hz.

2.4.2. Standby Mode

Standby mode is a low-power consumption mode. In standby mode, the internal core and I/O power domain are still active, but RF and TCXO are powered off, and the module stops satellites search and navigation. UART is still accessible through PMTK commands or any other data, but there is no NMEA messages output.

Sending PMTK command “\$PMTK161,0*28” will make GT-1110-MT module enter into standby mode. Sending any data via UART can wake the module up. When the module exits from standby mode, it will use all internal aiding information like GPS time, Ephemeris, Last Position, etc., resulting to the fastest possible TTFF in either Hot or Warm start. The typical standby current consumption in this way is about 1mA @VCC=3.3V.

- ✧ When the external active antenna is used, an additional 11mA will be consumed because the VCC still supplies power for external active antenna in standby mode.

2.4.3. Backup Mode

Backup mode consumes lower power than standby mode. In this mode, only the backup supply VBAT is powered on while the main supply VCC is switched off by host or the TIMER signal of GT-1110-MT. In order to enter into backup mode autonomously via the TIMER pin, an external switch circuit is necessary. The following figure has shown a typical reference design about the switch circuit for TIMER.

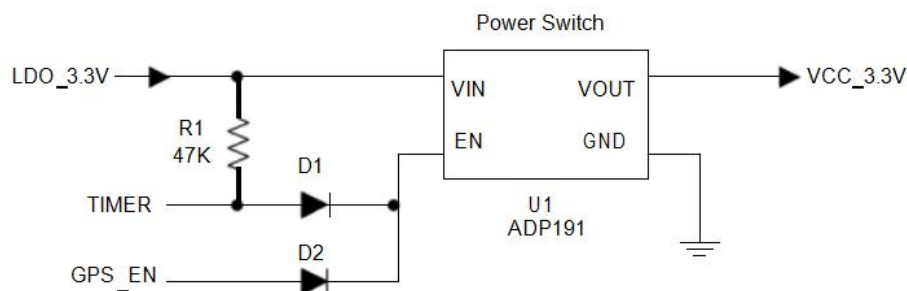
Figure 6: The External Switch Circuit for TIMER

- ✧ U1 is an integrated power switch component. The part number ADP191 is recommended. U1 also can be replaced by discrete components.
- ✧ TIMER pin also can be used to control the EN pin of a LDO.
- ✧ TIMER and GPS_EN signals form an “OR” logic via the Schottky diodes D1 and D2. GPS_EN is a GPIO signal coming from the host.
- ✧ TIMER is an open drain output signal. When TIMER pin is used, please pull it high by using an external resistor. R1 is the pull-up resistor for TIMER signal.

Keeping GPS_EN signal low and sending PMTK command“\$PMTK225,4*2F” will make GT-1110-MT module enter into backup mode forever. When this command is executed successfully, TIMER signal will be pulled down to close the power switch, so GT-1110-MT module can go into backup mode as the main power VCC is cut off. For this case, pulling the GPS_EN signal high by host is the only way to wake the module up.

In backup mode, GT-1110-MT module stops to acquire and track satellites. UART is not accessible. But the backed-up memory in RTC domain which contains all the necessary GPS information for quick start up and a small amount of user configuration variables is alive. Due to the backed up memory, EASY technology is available. The typical consumption in backup mode can be as low as 7uA.

As the main power supply for VBAT pin is battery. Coin-type rechargeable capacitor such as MS920SE from Seiko can be used and Schottky diode such as RB520S30T1G from ON Semiconductor is recommended to be used here for its low voltage drop.

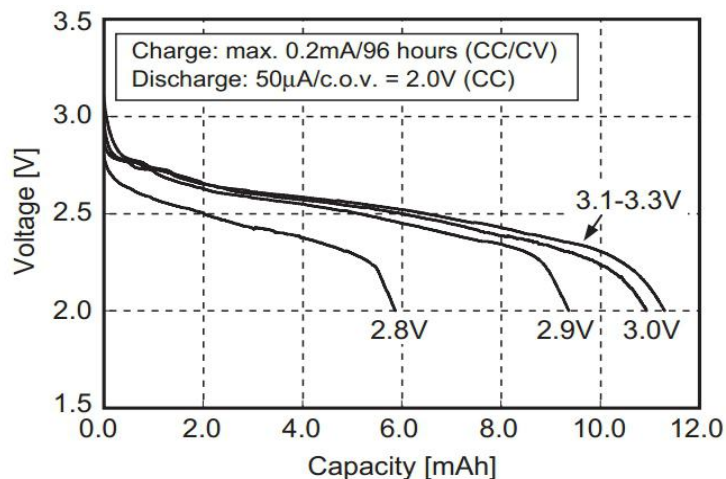

Figure 7: Seiko MS920SE Charge and Discharge Characteristics

2.4.4. Periodic Mode

Periodic mode is a power saving mode of GT-1110-MT that can control the full on mode and standby/backup mode periodically to reduce power consumption. It contains periodic standby mode and periodic backup mode.

✧ The format of the command which enables the module to enter into periodic mode is as follows:

Table 5: PMTK Command Format

Format:		
\$PMTK225,<Type>,<Run_time>,<Sleep_time>,<2nd_run_time>,<2nd_sleep_time>*<checksum> < CR><LF>		
Parameter	Format	Description
Type	Decimal	Type=1 for Periodic Backup Mode Type=2 for Periodic Standby Mode
Run_time	Decimal	Full on mode period (ms)
Sleep_time	Decimal	Standby/Backup mode period (ms)
2nd_run_time	Decimal	Full on mode period (ms) for extended acquisition in case GPS module's acquisition fails during the Run_time
2nd_sleep time	Decimal	Standby/Backup mode period (ms) for extended sleep in case GPS module's acquisition fails during the Run_time
Checksum	Hexadecimal	Hexadecimal checksum

Example

```
$PMTK225,1,3000,12000,18000,72000*16<CR><LF>
```

```
$PMTK225,2,3000,12000,18000,72000*15<CR><LF>
```

Sending "\$PMTK225,0*2B" in any time will make the module enter into full on mode from periodic standby mode.

Sending "\$PMTK225,0*2B" just in **Run_time** or **2nd_run_time** can make the module enter into full on mode from periodic backup mode.

- ✧ The precondition is that the external switch circuit supports periodic backup mode. For details, please refer to *chapter 2.4.3*.
- ✧ Before entering into periodic backup mode, please ensure the GPS_EN signal is low and power supply for VBAT is alive.

The following figure has shown the operation of periodic mode. When you send PMTK command, the module will be in the full on mode firstly. After several minutes, the module will enter into the periodic mode and follow the parameters set by you. When the module fails to fix the position in **run_time**, the module will switch to **2nd_run_time** and **2nd_sleep_time** automatically. As long as the module fixes the position again, the module will return to **Run_time** and **Sleep_time**.

Please ensure the module is in the tracking state before entering into periodic mode. Otherwise, the module will have a risk of failure to track the satellites. If GPS module is located in weak signal environment, it is better to set a longer **2nd_run_time** to ensure the success of re-acquisition.

The average current value can be calculated by the following formula:

$$I_{\text{periodic}} = (I_{\text{tracking}} \times T1 + I_{\text{standby/backup}} \times T2) / (T1 + T2) \quad T1: \text{Run_time}, T2: \text{Sleep_time}$$

Example

PMTK225,2,3000,12000,18000,72000*15 for periodic mode with 3s in tracking mode and 12s in standby mode. The average current consumption is calculated below:

$$I_{\text{periodic}} = (I_{\text{tracking}} \times T1 + I_{\text{standby}} \times T2) / (T1 + T2) = (20\text{mA} \times 3\text{s} + 1\text{mA} \times 12\text{s}) / (3\text{s} + 12\text{s}) \approx 4.8 \text{ (mA)}$$

PMTK225,1,3000,12000,18000,72000*16 for periodic mode with 3s in tracking mode and 12s in backup mode. The average current consumption is calculated below:

$$I_{\text{periodic}} = (I_{\text{tracking}} \times T1 + I_{\text{backup}} \times T2) / (T1 + T2) = (20\text{mA} \times 3\text{s} + 0.007\text{mA} \times 12\text{s}) / (3\text{s} + 12\text{s}) \approx 4.0 \text{ (mA)}$$

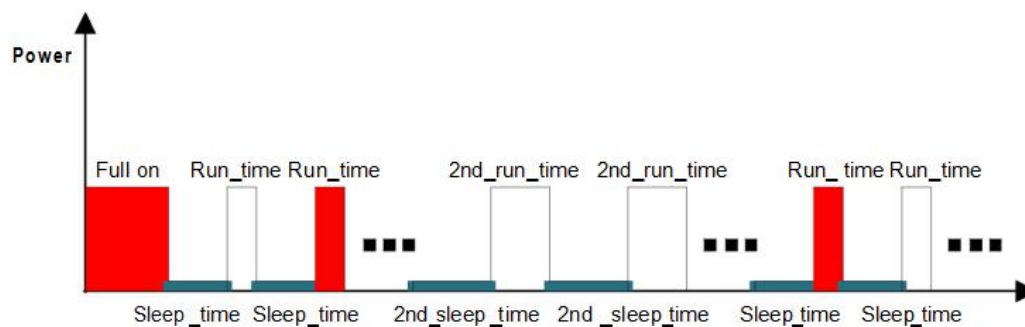

Figure 8: Periodic Mode

2.4.5. AlwaysLocate™ Mode

AlwaysLocate™ is an intelligent power saving mode. It contains AlwaysLocate™ backup mode and AlwaysLocate™ standby mode.

AlwaysLocate™ standby mode allows the module to switch automatically between full on mode and standby mode. According to the environmental and motion conditions, the module can adaptively adjust the full on time and standby time to achieve a balance between positioning accuracy and power consumption. Sending “\$PMTK225,8*23” and the module returning: “\$PMTK001,225,3*35” means the module accesses AlwaysLocate™ standby mode successfully. It will benefit power saving in this mode. Sending “\$PMTK225,0*2B” in any time will make the module back to full on mode.

AlwaysLocate™ backup mode is similar to AlwaysLocate™ standby mode. The difference is that AlwaysLocate™ backup mode can switch between full on mode and backup mode automatically. The PMTK command to enter into AlwaysLocate™ backup mode is “\$PMTK225,9*22”. The module can exit from AlwaysLocate™ backup mode by command “\$PMTK225,0*2B” sent just after the module has been waked up from previous backup cycle.

The positioning accuracy in AlwaysLocate™ mode will be somewhat degraded, especially in high speed. The following picture shows the rough power consumption of GT-1110-MT module in different daily scenes when AlwaysLocate™ mode is enabled.

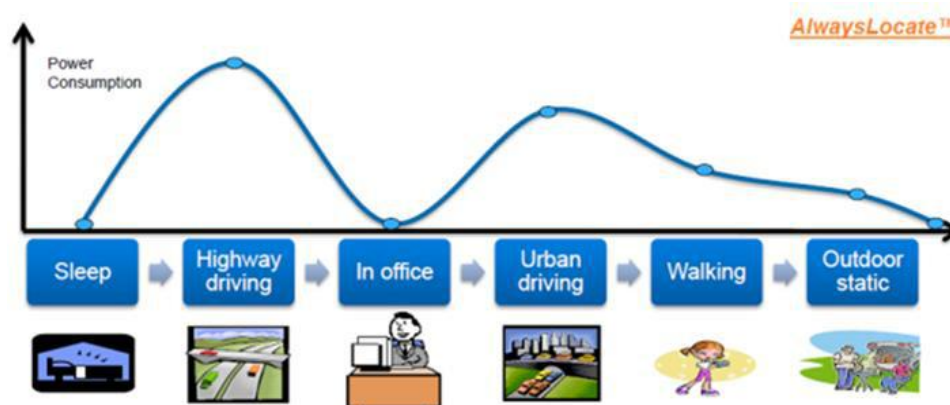

Figure 9: AlwaysLocate™ Mode

Example

The typical average consumption is about 3.5mA in AlwaysLocate™ standby mode and 3.0mA in AlwaysLocate™ backup mode.

- ✧ Power consumption is measured under outdoor static mode with patch antenna. Using external active antenna will increase the power consumption.
- ✧ Before entering into periodic backup mode, please ensure the GPS_EN signal is low and power supply for VBAT is alive.

2.4.6. FLP Mode

The Fitness Low Power (FLP) feature provides low power GPS solution for fitness application. FLP is a duty cycle concept to achieve low power target. It is specifically designed for walking/running/cycling applications.

FLP function is disabled by default. You can enable FLP by SDK or PMTK command. Sending “\$PMTK262,1*29” will enable FLP function, and wait until GT-1110-MT module gets a valid fix. Then wait at least 60s for GT-1110-MT to enter FLP mode. FLP function will be disabled after sending “\$PMTK262,0*28”.

Table 6: Average Current for FLP Mode and Tracking Mode of GT-1110-MT.

Scenario	In FLP Mode (mA)	In Tracking Mode (mA)
Static	11.3	20
Walking	10.9	20
Running	10.7	20
Driving	11.4	20

- ◇ The EASY and FLP function cannot work at the same time. When you enable FLP by SDK or PMTK command, the EASY function will be disabled automatically.
- ◇ SBAS data downloading will be influenced by FLP function. It is suggested that you should disable the SBAS while enabling FLP mode.
- ◇ The power consumption is measured in the open sky under different states of motion.
- ◇ The current is the average of multiple measurements.

2.5. UART Interface

The module provides one universal asynchronous receiver& transmitter serial port. The module is designed as DCE (Data Communication Equipment), following the traditional DCE-DTE (Data Terminal Equipment) connection. The module and the client (DTE) are connected through the signals shown in the following figure. It supports data baud-rate from 4800bps to 115200bps.

UART port:

TXA: Send data to the RXD signal line of DTE.

RXA: Receive data from the TXD signal line of DTE.

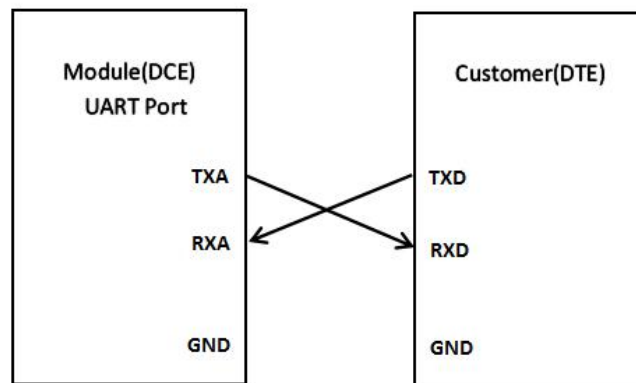

Figure 10: Connection of Serial Interfaces

This UART port has the following features:

- UART port can be used for firmware upgrade, NMEA output and PMTK proprietary commands input.
- The default output NMEA type setting is RMC, VTG, GGA, GSA, GSV, GLL
- UART port supports the following data rates:
4800, 9600, 14400, 19200, 38400, 57600, 115200bps.
The default setting is 9600bps, 8 bits, no parity bit, 1 stop bit.
- Hardware flow control and synchronous operation are not supported.

The UART port does not support the RS-232 level but only CMOS level. If the module's UART port is connected to the UART port of a computer, it is necessary to add a level shift circuit between the module and the computer. Please refer to the following figure.

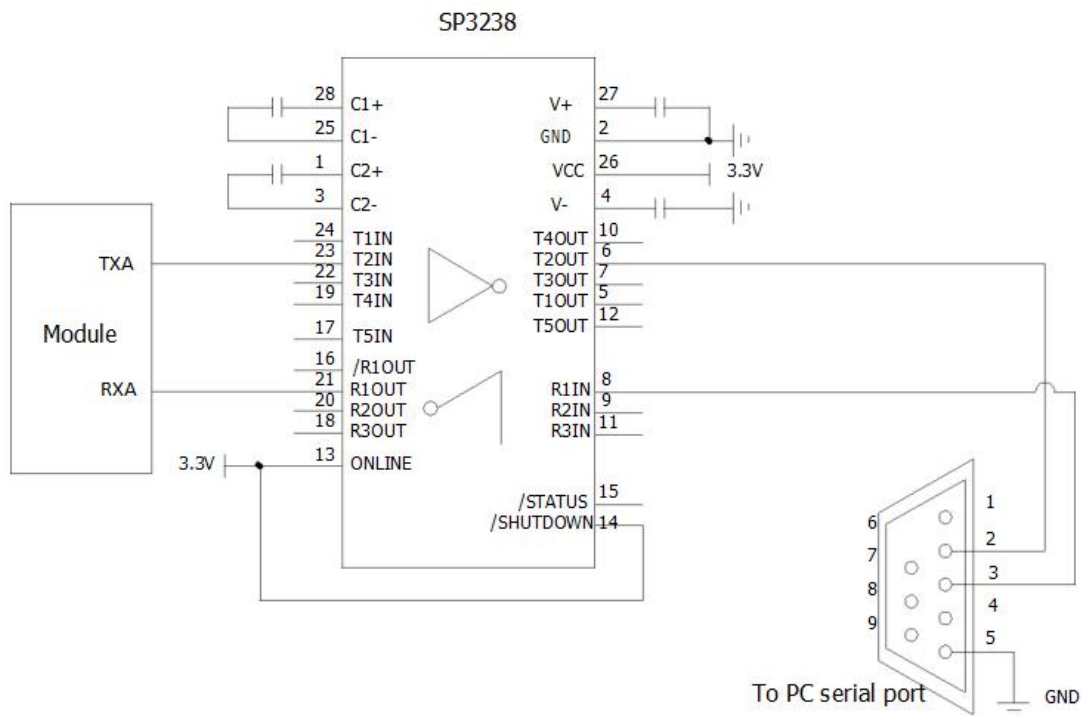

Figure 11: RS-232 Level Shift Circuit

2.6. EASY Technology

EASY technology works as embedded software which can accelerate TTFB by predicting satellite navigation messages from received ephemeris. The GPS engine will calculate and predict orbit.

information automatically up to 3 days after first receiving the broadcast ephemeris, and then save the predicted information into the internal memory. GPS engine will use the information for positioning if no enough information from satellites, so the function is helpful for positioning and TTFF improvement.

The EASY function can reduce TTFF to 5s in warm start. In this case, RTC domain should be valid. In order to get enough broadcast ephemeris information from GPS satellites, the GPS module should receive the information for at least 5 minutes in good signal conditions after fixing the position.

EASY function is enabled by default. Command “\$PMTK869,1,0*34” can be used to disable EASY.

2.7. Multi-tone AIC

GT-1110-MT module provides an advanced technology called multi-tone AIC (Active Interference Cancellation) to reject RF interference which comes from other active components on the main board.

Up to 12 multi-tone AIC embedded in the module can provide effective narrow -band interference and jamming elimination. The GPS signal could be recovered from the jammed signal, which can ensure better navigation quality. AIC is enabled by default, closing it will save about 1mA @VCC=3.3V consumption. The following commands can be used to set AIC.

Enable AIC function: “\$PMTK 286,1*23”.

Disable AIC function: “\$PMTK 286,0*22”.

2.8. LOCUS

GT-1110-MT module supports the embedded logger function called LOCUS. It can log position information to the internal flash memory automatically when this function is enabled by sending PMTK command “\$PMTK183,0*22”. Due to this function, the host can go to sleep to save power consumption and does not need to receive the NMEA information all the time. The module can provide a log capacity of more than 16 hours.

The detail procedures of this function are illustrated below:

- The module has fixed the position (only 3D_fixed is available);
- Sending PMTK command “\$PMTK184,1*22” to erase internal flash;
- Sending PMTK command “\$PMTK185,0*22” to start log;
- Module logs the basic information (UTC time, latitude, longitude and height) every 15 seconds to internal flash memory;
- Stop logging the information by sending “\$PMTK185,1*23”;
- Host can get the data from the module via UART by sending “\$PMTK622,1*29”.

The raw data which host gets has to be parsed via LOCUS parser code provided by GOTOP. For more details, please contact GOTOP technical supports.

2.9. PPS VS. NMEA

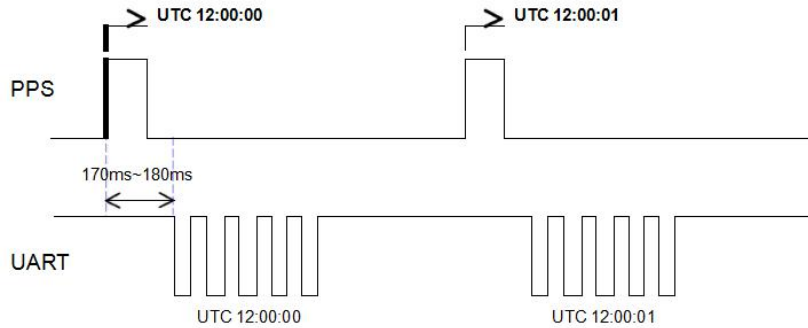

Figure 12: PPS VS. NMEA Timing

This feature only supports 1Hz NMEA output and baud rate at 14400~115200bps. At baud rate of 9600 and 4800bps, it only supports RMC NMEA sentence. Because at low baud rate, per second transmission may exceed one second if there are many NMEA sentences output. You can enable this function by sending “\$PMTK255,1*2D”, and disable the function by sending “\$PMTK255,0*2C”.

3 Antenna Interfaces

3.1. PCB Design Guide

The GT-1110-MT GPS receiver is designed for supporting the active antenna or passive antenna connected with pin RF_IN. The gain of active antenna should be no less than 15dB. The maximum noise figure should be no more than 2.5dB and output impedance is at 50 Ohm.

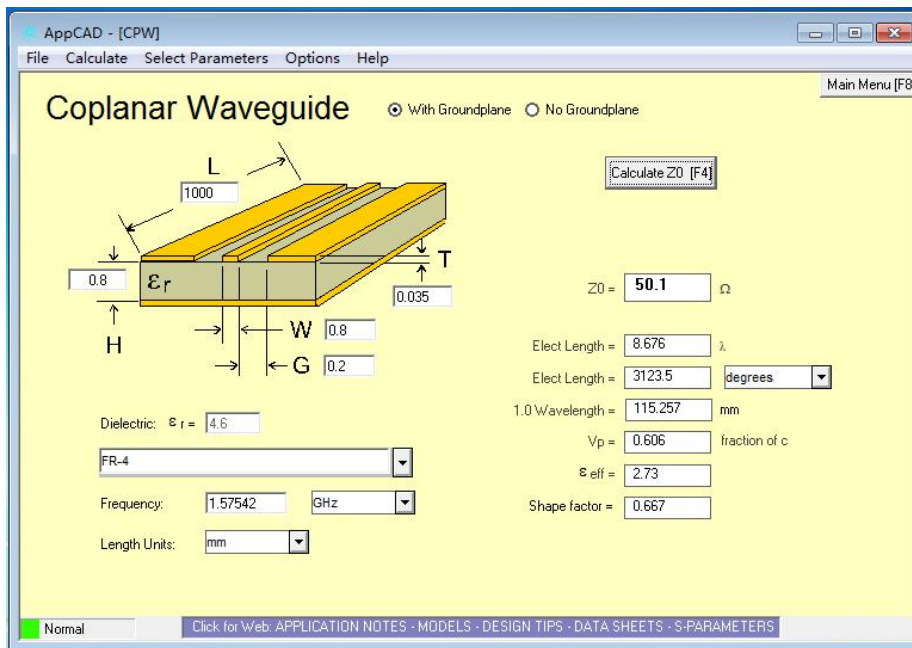

Figure 13: Antenna design requirements

3.2. External Active Antenna

The following figure is a typical reference design with active antenna. In this mode, DC on the VCC_RF pin is powered by VCC and supplies power to the external active antenna.

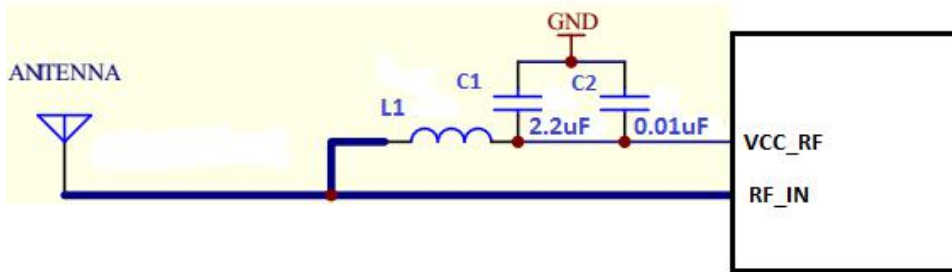

Figure 14: Reference Design for Active Antenna

C1, C2, L1 is used for power supply and filtering effect to the external active antenna, RF_IN antenna to a circuit part (BOLD line) for high frequency microstrip line, PCB in the design of this part of the line to calculate the characteristic impedance of the high-frequency line according to the principle of high frequency wiring.

- ✧ Requirements: this section of the line in the 1575.42MHz frequency characteristic impedance requirement is 50 ohm.

Table 7: Recommended Active Antenna Specification

Antenna Type	Specification
Active Antenna	Center frequency: 1575.42MHz Band width: >5MHZ VSWR: <2 (Typ.) Polarization: RHCP or Linear Noise figure: <1.5dB Gain (antenna): >-2dBi Gain (embedded LNA): 20dB (Typ.) Total gain: >18dBi(Typ.)

4 Electrical, Reliability and Radio Characteristics

4.1. Absolute Maximum Ratings

Absolute maximum ratings for power supply and voltage on digital pins of the module are listed in the following table.

Table 8: Absolute Maximum Ratings

values within the specified boundaries by using appropriate protection diodes.

Parameter	Min.	Max.	Unit
Power Supply Voltage (VCC)	-0.3	4.3	V
Backup Battery Voltage (VBAT)	-0.3	4.3	V
Input Voltage at Digital Pins	-0.3	3.6	V
Input Power at RF_IN		15	dBm
Storage Temperature	-45	125	°C

✧ Stressing the device beyond the “Absolute Maximum Ratings” may cause permanent damage. These are stress ratings only. The product is not protected against over voltage or reversed voltage. If necessary, voltage spikes exceeding the power supply voltage specification, given in table above, must be limited to values within the specified boundaries by using appropriate protection diodes.

✧

4.2. Operating Conditions

Table 9: Power Supply Ratings

Parameter	Description	Conditions	Min.	Typ.	Max.	Unit
VCC	Supply voltage	Voltage must stay within the min/max values, including voltage drop, ripple, and spikes.	2.8	3.3	4.3	V
IVCCP	Peak supply current	VCC=3.3V			100	mA
VBAT	Backup voltage supply		1.5	3.3	4.3	V
TOPR	Normal operating temperature		-40	25	80	°C

✧ The figure IVCCP can be used to determine the maximum current capability of power supply.

- ✧ Operation beyond the "Operating Conditions" is not recommended and extended exposure beyond the "Operating Conditions" may affect the device's reliability.

4.3. Current Consumption

The values for current consumption are shown in the following table.

Table 10: Current Consumption

Parameter	Conditions	Min.	Typ.	Max.	Unit
I _{VCC} @Acquisition	VCC=VBAT=3.3V		40		mA
I _{VCC} @Tracking	VCC=VBAT=3.3V		35		mA
I _{VCC} @Standby	VCC=VBAT=3.3V		2.0		mA
I _{BCKP} @Backup	VBAT=3.3V		15		uA

The tracking current is tested in the following conditions:

- ✧ In Cold Start, 10 minutes after First Fix.
- ✧ In Hot Start, 15 seconds after First Fix.

4.4. Electrostatic Discharge

GT-1110-MT module is an ESD sensitive device. ESD protection precautions should still be emphasized. Proper ESD handling and packaging procedures must be applied throughout the processing, handling and operation of any application.

The ESD bearing capability of the module is listed in the following table. Note that you should add ESD components to module pins in particular applications.

Table 11: ESD Endurance Table (Temperature : 25°C, Humidity: 45%)

Pin	Contact Discharge	Air Discharge
RF_IN	±5KV	±10KV
Patch Antenna	±5KV	±10KV
VCC	±5KV	±10KV
UART	±3KV	±6KV
Others	±2KV	±4KV

4.5. Reliability Test

Table 12: Reliability Test

Test Item	Conditions	Standard
Thermal Shock	-30°C...+80°C, 144 cycles	GB/T 2423.22-2002 Test Na IEC 68-2-14 Na
Damp Heat, Cyclic	+55°C; >90% Rh 6 cycles for 144 hours	IEC 68-2-30 Db Test
Vibration Shock	5~20Hz, 0.96m2/s3; 20~500Hz, 0.96m2/s3-3dB/oct, 1hour/axis; no function	2423.13-1997 Test Fdb IEC 68-2-36 Fdb Test
Heat Test	85°C, 2 hours, operational	GB/T 2423.1-2001 Ab IEC 68-2-1 Test
Cold Test	-40°C, 2 hours, operational	GB/T 2423.1-2001 Ab IEC 68-2-1 Test
Heat Soak	90°C, 72 hours, non-operational	GB/T 2423.2-2001 Bb IEC 68-2-2 Test B
Cold Soak	-45°C, 72 hours, non-operational	GB/T 2423.1-2001 A IEC 68-2-1 Test

5 Mechanical Dimensions

This chapter describes the mechanical dimensions of the module.

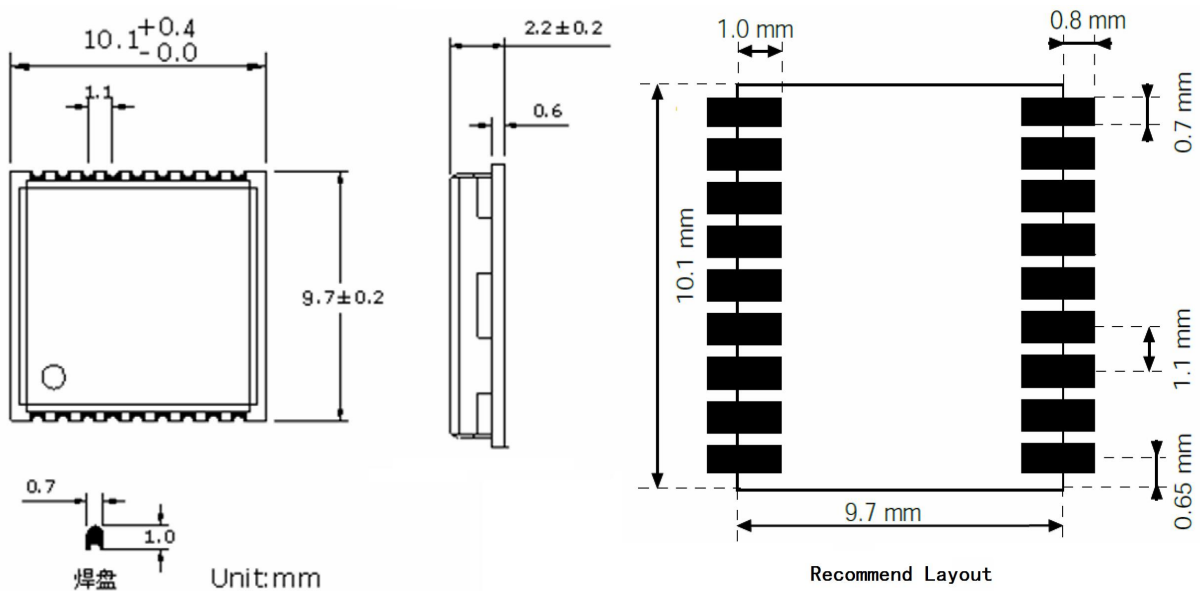

Figure 15: Top View Dimensions

6 Manufacturing, Packaging and Ordering Information

6.1. Assembly and Soldering

GT-1110-MT module is intended for SMT assembly and soldering in a Pb-free reflow process on the top side of the PCB. It is suggested that the minimum height of solder paste stencil is 100um to ensure sufficient solder volume. Pad openings of paste mask can be increased to ensure proper soldering and solder wetting over pads. It is suggested that the peak reflow temperature is 235~245° C (for SnAg3.0Cu0.5 alloy). The absolute maximum reflow temperature is 260° C. To avoid damage to the module when it is repeatedly heated, it is suggested that the module should be mounted after reflow soldering for the other side of PCB has been completed. Recommended reflow soldering thermal profile is shown below:

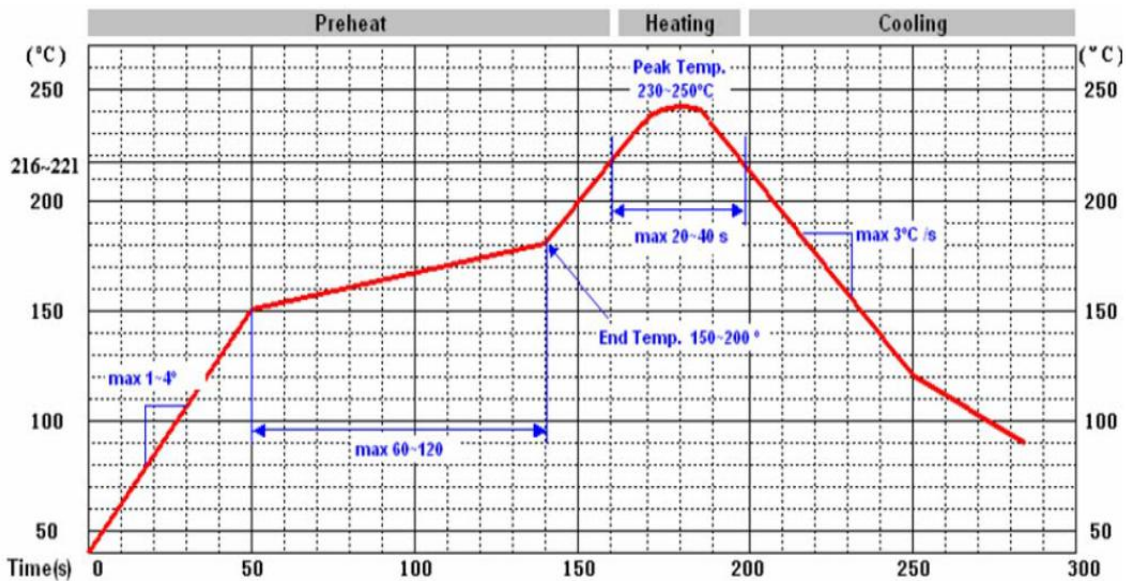

Figure 16: Recommended Reflow Soldering Thermal Profile

6.2. Moisture Sensitivity

GT-1110-MT module is sensitive to moisture. To prevent GT-1110-MT from permanent damage during reflow soldering, baking before reflow soldering is required in following cases:

- ◇ Humidity indicator card: One or more indicating spots are no longer blue.
- ◇ The seal is opened and the module is exposed to excessive humidity.

GT-1110-MT should be baked for 192 hours at temperature 40°C+5°C/-0°C and <5% RH in low-temperature containers, or 24 hours at temperature 125°C±5°C in high-temperature containers. Care should be taken that the plastic tape is not heat resistant. GT-1110-MT should be taken out from the tape before preheating; otherwise, the tape maybe damaged by high-temperature heating.

6.3. ESD Protection

GT-1110-MT module is sensitive to ESD and requires special precautions when handling. Particular care must be exercised when handling patch antenna, duo to the risk of electrostatic charges.

6.4. Tape and Reel Packaging

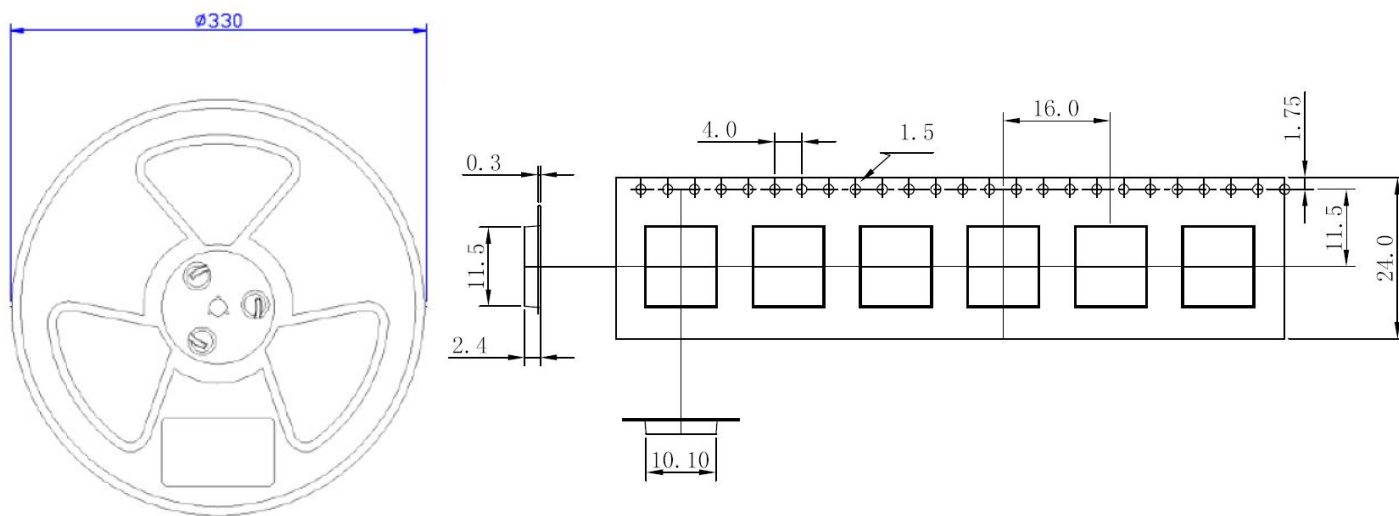

Unit: mm

Quantity per reel: 1000pcs

Length per reel: 16m

Figure 17: Tape and Reel Specifications



Figure 18: Packaging physical Figure

Table13: Reel Packaging

Model Name	MOQ for MP	Minimum Package: 1000pcs
GT-1110-MT	1000pcs	Size: 365mm × 350mm × 53mm N.W: 0.87kg G.W: 1.05kg

7 Appendix References

Table 14: Terms and Abbreviations

Abbreviation	Description
AGPS	Assisted GPS
AIC	Active Interference Cancellation
CEP	Circular Error Probable
DGPS	Differential GPS
EASY	Embedded Assist System
EGNOS	European Geostationary Navigation Overlay Service
EPO	Extended Prediction Orbit
ESD	Electrostatic Discharge
GPS	Global Positioning System
GNSS	Global Navigation Satellite System
GGA	GPS Fix Data
GLL	Geographic Position – Latitude/Longitude
GLONASS	Global Navigation Satellite System
GSA	GNSS DOP and Active Satellites
GSV	GNSS Satellites in View
HDOP	Horizontal Dilution of Precision
I/O	Input/Output
Kbps	Kilo Bits Per Second
LNA	Low Noise Amplifier
MSAS	Multi-Functional Satellite Augmentation System
MOQ	Minimum Order Quantity
NMEA	National Marine Electronics Association
PDOP	Position Dilution of Precision
PMTK	MTK Proprietary Protocol
PPS	Pulse Per Second
PRN	Pseudo Random Noise Code
QZSS	Quasi-Zenith Satellite System
RHCP	Right Hand Circular Polarization
RMC	Recommended Minimum Specific GNSS Data
SBAS	Satellite-based Augmentation System
SAW	Surface Acoustic Wave
SPDT	Single-Pole Double-Throw
TTFF	Time To First Fix

UART	Universal Asynchronous Receiver & Transmitter
VDOP	Vertical Dilution of Precision
VTG	Course over Ground and Ground Speed, Horizontal Course and Horizontal Velocity
WAAS	Wide Area Augmentation System
Inom	Nominal Current
Imax	Maximum Load Current
Vmax	Maximum Voltage Value
Vnom	Nominal Voltage Value
Vmin	Minimum Voltage Value
VIHmax	Maximum Input High Level Voltage Value
VIHmin	Minimum Input High Level Voltage Value
VILmax	Maximum Input Low Level Voltage Value
VILmin	Minimum Input Low Level Voltage Value
VImax	Absolute Maximum Input Voltage Value
Vimin	Absolute Minimum Input Voltage Value
VOHmax	Maximum Output High Level Voltage Value
VOHmin	Minimum Output High Level Voltage Value
VOLmax	Maximum Output Low Level Voltage Value
VOLmin	Minimum Output Low Level Voltage Value

8 NMEA 0183 Protocol

The NMEA protocol is an ASCII-based protocol, Records start with a \$ and with carriage return/line feed. GPS specific messages all start with \$GPxxx where xxx is a three-letter identifier of the message data that follows. NMEA messages have a check sum, which allows detection of corrupted data transfers.

The Gotop GT-1110-MT supports the following NMEA-0183 messages: \$GPGGA, \$GPGLL,\$GPGSA,\$GP GSV, \$GPRMC and \$GPVTG.

Table 15: NMEA-0183 Output Messages

NMEA Record	DESCRIPTION
GGA	Global positioning system fixed data
GLL	Geographic position—latitude/longitude
GSA	GNSS DOP and active satellites
GSV	GNSS satellites in view
RMC	Recommended minimum specific GNSS data
VTG	Course over ground and ground speed

8.1 GGA-Global Positioning System Fixed Data

\$GPGGA, 161229.487,3723.2475,N, 12158.3416,W, 1,07,1.0,9.0,M.0000*18

Table 16: GGA Data Format

Name	Example	Units	Description
Message ID	\$GPGGA		GGA protocol header
UTC Position	161229.487		hhmmss.sss
Latitude	3723.2457		ddmm.mmmm
N/S indicator	N		N=north or S=south
Longitude	12158.3416		dddmm.mmmm
E/W Indicator	W		E=east or W=west
Position Fix Indicator	1		See Table 16-1
Satellites Used	07		Range 0 to 12
HDOP	1.0		Horizontal Dilution of Precision
MSL Altitude	9.0	meters	
Units	M	meters	
Geoids Separation		meters	
Units	M	meters	
Age of Diff.Corr.		second	Null fields when DGPS is not Used
Diff.Ref.Station ID	0000		
Check sum	*18		
<CR> <LF>			End of message termination

Table 16-1: Position Fix Indicators

Value	Description
0	Fix not available or invalid
1	GPS SPS Mode, fix valid
2	Differential GPS, SPS Mode, fix valid
3	GPS PPS Mode, fix valid

8.2 GLL-Geographic Position - Latitude/Longitude

\$GPGLL , 3723.2475, N,12158.3416, W,161229.487, A*2C.

Table 17: GLL Data Format

Name	Example	Units	Description
Message ID	\$GPGLL		GLL protocol header
Latitude	3723.2475		ddmm.mmmmm
N/S Indicator	N		N=north or S=south
Longitude	12158.3416		dddmm.mmmmm
E/W Indicator	W		E=east or W=west
UTC Position	161229.487		hhmmss.sss
Status	A		A=data valid or V=data not valid
Check sum	*2C		
<CR> <LF>			End of message termination

8.3 GSA-GNSS DOP and Active Satellites

\$GPGSA , A, 3, 07, 02, 26,27, 09, 04,15, , , , , , 1.8,1.0,1.5*33.

Table18: GSA Data Format

Name	Example	Units	Description
Message	\$GPGSA		GSA protocol header
Mode 1	A		See Table 18-2
Mode 2	3		See Table 18-1
Satellite Used	07		Sv on Channel 1
Satellite Used	02		Sv on Channel 2
...
Satellite Used			Sv on Channel 12
PDOP	1.8		Position Dilution of Precision
HDOP	1.0		Horizontal Dilution of Precision
VDOP	1.5		Vertical Dilution of Precision
Check sum	*33		
<CR> <LF>			End of message termination

Table 18-1: Mode 1

Value	Description
1	Fix not available
2	2D
3	3D

Table 18-2: Mode 2

Value	Description
M	Manual-forced to operate in 2D or 3D mode
A	Automatic-allowed to automatically switch 2D/3D

8.4 GSV-GNSS Satellites in View

\$GPGSV , 2, 1, 07, 07, 79,048, 42, 02, 51,062, 43, 26, 36,256, 42, 27, 27, 138,42*71

\$GPGSV , 2, 2, 07, 09, 23,313, 42, 04, 19, 159, 41, 15,12,041, 42*41.

Table 19: GGA Data Format

Name	Example	Units	Description
Message ID	\$GPGSV		GSV protocol header
Number of Message	2		Range 1 to 3
Message Number	1		Range 1 to 3
Satellites in View	07		
Satellite ID	07		Channel 1(Range 1 to 32)
Elevation	79	degrees	Channel 1(Maximum 90)
Azinmuth	048	degrees	Channel 1(True, Range 0 to 359)
SNR(C/NO)	42	dBHz	Range 0 to 99,null when not tracking
...			...
Satellite ID	27		Channel 4(Range 1 to 32)
Elevation	27	degrees	Channel 4(Maximum 90)
Azimuth	138	degrees	Channel 4(True, Range 0 to 359)
SNR(C/NO)	42	dBHz	Range 0 to 99, null when not tracking
Check sum	*71		
<CR> <LF>			End of message termination

✧ Depending on the number of satellites tracked multiple messages of GSV data may be required.

8.5 RMC-Recommended Minimum Specific GNSS Data

\$GPRMC, 161229.487, A, 3723.2475, N, 12158.3416, W, 0.13,309.62, 120598,, *10

Table 20: RMC Data Format

Name	Example	Units	Description
Message ID	\$GPRMC		RMC protocol header
UTS Position	161229.487		hhmmss.sss
Status	A		A=data valid or V=data not valid
Latitude	3723.2475		ddmm.mmmm
N/S Indicator	N		N=north or S=south
Longitude	12158.3416		dddmm.mmmm
E/W Indicator	W		E=east or W=west
Speed Over Ground	0.13	Knots	
Course Over Ground	309.62	Degrees	True
Ground			
Date	120598		dummy
Magnetic variation		Degrees	E=east or W=west
Check sum	*10		
<CR> <LF>			End of message termination

8.6 VTG-Course Over Ground and Ground Speed

\$GPVTG, 309.62, T, M, 0.13, N, 0.2, K*6E

Table 21: VTG Data Format

Name	Example	Units	Description
Message ID	\$GPVTG		VTG protocol header
Course	309.62	Degrees	Measured heading
Reference	T		True
Course		Degrees	Measured heading
Reference	M		Magnetic
Speed	0.13	Knots	Measured horizontal speed
Units	N		Knots
Speed	0.2	Km/hr	Measured horizontal speed
Units	K		Kilometer per hour
Check sum	*6E		
<CR> <LF>			End of message termination

©Copyright 2020 Gotop Technology Co., Ltd. All Right Reserved

The information contained herein is subject to change without notice.

Gotop Technology Co. , LTD

Add:AreaC,4th layer,A1 building,QingHu Silicon Valley Power,LongHua district ,Shenzhen ,China

Phone: 86-755-23804156

fax: 86-755-23804155

N 22° 32' 17", E 114° 07' 07"

<http://www.gotop-zzu.com>

Not to be reproduced in whole or part for any purpose without written permission of Gotop Technology Inc ('Gotop'). Information provided by Gotop is believed to be accurate and reliable. These materials are provided by Gotop as a service to its customers and may be used for informational purposes only. Gotop assumes no responsibility for errors or omissions in these materials, nor for its use. Gotop reserves the right to change specification at any time without notice.

These materials are provides 'as is' without warranty of any kind, either expressed or implied, relating to sale and/or use of Gotop products including liability or warranties relating to fitness for a particular purpose, consequential or incidental damages, merchantability, or infringement of any patent, copyright or other intellectual property right. Gotop further does not warrant the accuracy or completeness of the information, text, graphics or other items contained within these materials. Gotop shall not be liable for any special, indirect, incidental, or consequential damages, including without limitation, lost revenues or lost profits, which may result from the use of these materials.

Gotop products are not intended for use in medical, life-support devices, or applications involving potential risk of death, personal injury, or severe property damage in case of failure of the product.